

V. V. KOZLOV

Department of Mechanics and Mathematics
Moscow State University, Vorob'iev Gory
119899, Moscow, Russia
E-mail: vako@mech.math.msu.su

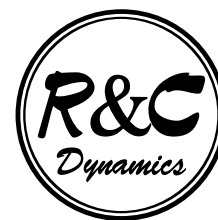

KINETICS OF COLLISIONLESS CONTINUOUS MEDIUM

Received June 8, 2001

DOI: 10.1070/RD2001v006n03ABEH000175

In this article we develop Poincaré ideas about a heat balance of ideal gas considered as a collisionless continuous medium. We obtain the theorems on diffusion in nondegenerate completely integrable systems. As a corollary we show that for any initial distribution the gas will be eventually irreversibly and uniformly distributed over all volume, although every particle during this process approaches arbitrarily close to the initial position indefinitely many times. However, such individual returnability is not uniform, which results in diffusion in a reversible and conservative system. Balancing of pressure and internal energy of ideal gas is proved, the formulas for limit values of these quantities are given and the classical law for ideal gas in a heat balance is deduced. It is shown that the increase of entropy of gas under the adiabatic extension follows from the law of motion of a collisionless continuous medium.

1. Heat balance

The establishment of heat balance of gas in a vessel is one of the central problems of nonequilibrium statistical mechanics. The conventional model is Boltzmann–Gibbs gas: ensemble of a large (but finite) number of identical solid balls elastically colliding with each other and with the walls of the vessel. According to the classical approach based on the Boltzmann kinetic equation the process starts with practically instantaneous establishment of the Maxwell velocity distribution, and then (not so fast and with oscillations) the gas density becomes balanced [1].

Unfortunately, such approach involve several fundamental difficulties. First, the Boltzmann equation is approximate. It does not take into account multiple collisions, and, besides this approach assumes the statistical independence of the number of pair collisions. This assumption (Stosszahlansatz by P. Ehrenfest and T. Ehrenfest [2]) is plausible, but it certainly does not follow immediately from the dynamics of the Boltzmann–Gibbs gas model. Furthermore, there are difficulties in an adjustment of the solutions of the Boltzmann equation with the reversibility property of the dynamics equations and with the Poincaré theorem on returning (see [3, 4] for the discussion of these problems).

Logical opportunity of the adjustment of the irreversible behavior of a system with the properties of reversibility and returnability was shown by M. Kac [4, 5] on a so-called *circular model*, which, however, is not related to the gas theory. A phase space in the Kac model is an ensemble of white and black balls in vertexes of regular n -gon. Besides, a set M of vertexes of n -gon consisting of $m < n/2$ elements is selected. The dynamics of the circular model is determined by rotation on one element counter-clockwise. If a ball does not belong to the set M , its color does not change, and if it belongs to M , the color of the ball changes to the opposite. The dynamics of such system is clearly invariant relatively to the direction of rotation (reversibility). It is also possible to verify that after $2n$ rotations the system will turn into the initial state (returnability).

Let $N_c(t)$ and $N_b(t)$ be the numbers of black and white balls in integer moments of time t . As Kac has proved, the mean value of the ratio

$$\left\langle \frac{N_c(t) - N_b(t)}{n} \right\rangle,$$

Mathematics Subject Classification 37H10, 70F45

calculated over all possible states of the set M , decreases for $n \rightarrow \infty$ as $(1 - 2\mu)^t$, where μ is a limit value of ratio m/n . Thus, if $\mu < 1/2$ then after the large enough period of time the average number of white and the average number of black balls will coincide.

The Kac circular model is an advanced version of earlier Ehrenfests' model [2], that possessed only the property of reversibility. The model also shows a characteristic feature of the conventional of reasoning in statistical mechanics: evaluation of average values, passage to the limit on the number of particles ($n \rightarrow \infty$), and then passage to the limit on time ($t \rightarrow \infty$). The latter limit is connected with the fact that the average returning time tends to infinity together with n , hence one should choose a time interval, which is less than the order of this quantity.

Actually, the justification of thermodynamics involves additional difficulties of a different kind. The matter is that *the ideal gas* is considered as a system of noninteracting particles. In particular, they cannot collide with each other. It is under this assumption that the perfect gas law is deduced in statistical mechanics. On the contrary, when the interaction is taken into account (in particular, assuming the possibility of collisions is), then using the canonical Gibbs distribution we obtain the equation of state, different from the classical Clapeyron equation (see [6]).

On the other hand, as it is shown in papers [7, 8], the Clapeyron equation is deduced from the general principles of statistical mechanics under the assumption that the density of distribution of probabilities is a single-valued function of the total energy of system of particles. It should be emphasized that this function does not necessarily coincide with the density of Maxwell distribution.

The ideal gas is the fundamental model of mechanics of a continuous medium and statistical mechanics. Therefore, the problem of justification of irreversible behavior of ideal gas that does not require the Boltzmann mechanism of pair collisions gains a special importance. And it is not at all obvious that such irreversibility mechanism actually exists.

These problems constitute the subject of the present paper.

2. The ideal gas as a collisionless continuous medium

The above mentioned difficulties can be overcome if the ideal gas is considered as a *collisionless continuous medium*. It is necessary to note that the hypothesis on the continuity property of gas is in good agreement with the continuity of velocity distribution of gas particles.

Besides, collisionless models play an essential role in many parts of mathematical physics. As an example, the theory by Ya. B. Zeldovich could be mentioned that explains an occurrence of inhomogeneities in a distribution of pulverulent substance in the Universe (see [9]). Another important example is the Burgers equation. It describes the dynamics of fluid without pressure and is one of possible simplifications of the Navier–Stokes equations [10]. Multidimensional hydrodynamics of invariant manifolds of Hamiltonian systems, developed in work [11], also describes the evolution of a collisionless medium.

For the first time, the ideal gas has, apparently, been considered as a collisionless continuous medium by H. Poincaré in [12]. He studied the behavior of ideal gas in a rectangular parallelepiped

$$\Pi^n = \{0 \leq z_1 \leq l_1, \dots, 0 \leq z_n \leq l_n\}$$

(l_s being the edges of the parallelepiped) for $n = 1, 2$ and 3 . Poincaré called such gas *one-dimensional*. In Poincaré's terminology, *three-dimensional gas* is consisted of molecules, which can collide with each other. His basic observation was that, independently of the initial distribution, gas eventually tends to uniform filling of Π . Thus, the ideal gas shows the irreversible behavior. Every particle of gas approaches arbitrarily close to the initial position infinitely many times. However, because of nonuniformity of the returnability property, a nonreversible *diffusion* of gas occurs. Besides, the equations of motion of a collisionless medium are invariant under reflection of time $t \mapsto -t$. Thus, as far back as in 1906 Poincaré showed on the simplified model (directly related to the kinetic theory) the

compatibility of the reversibility and returnability properties with irreversible behavior of a dynamical system.

Unfortunately, these remarkable ideas of Poincaré were not properly understood and remained unclaimed. I have not found any work on statistical mechanics that mentions his ideas in connection with the problem of irreversibility. The comments to the Poincaré’s work of 1906 in volume III of the Russian edition of his collected works completely miss the point.

Some interesting works on the kinetic theory, that also use the model of collisionless medium, have appeared recently. As an example we shall mention *the dynamical demon of Maxwell* [13, 14]. However, they do not refer to the Poincaré’s pioneer works.

Of course, Poincaré has considered only the most simple variants and his works do not contain precise statements with complete and rigorous proofs in modern understanding of these words. However, his ideas finally (after almost 100 years) deserve an involvement into the area of study of modern nonequilibrium statistical mechanics. The purpose of the present paper is the development of the Poincaré’s ideas on heat balance of ideal gas as a collisionless continuous medium.

So, we consider the dynamics of particles in a n -dimensional parallelepiped Π^n . Clearly, Π^n allows a natural 2^n -leaf covering by n -dimensional torus $\mathbb{T}^n = \{x_1, \dots, x_n \text{ mod } 2\pi\}$ with branching on the boundary of Π^n . Variables x and z are related as follows: $x = \pi z/l$ if z increases from 0 up to l , and $x = 2\pi - \pi z/l$ if z decreases from l to 0 (Fig. 1).

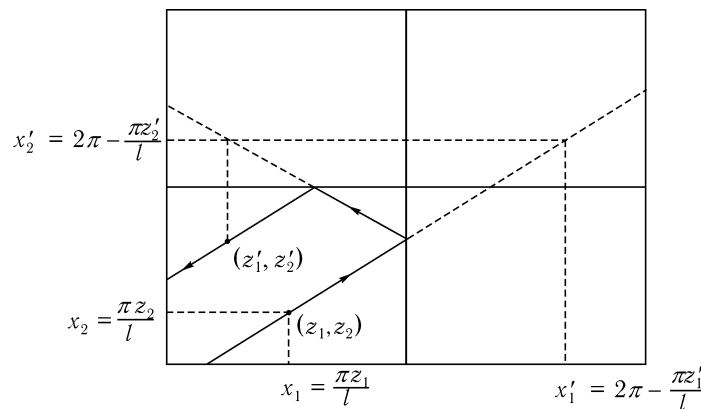

Fig. 1

Let v_1, \dots, v_n be the velocity components of a gas particle in $\Pi^n \subset \mathbb{R}^n = \{z\}$. Then the rates of variation of its x -coordinate are equal to

$$\omega_1 = \frac{\pi v_1}{l_1}, \dots, \omega_n = \frac{\pi v_n}{l_n}. \tag{2.1}$$

Hence, in variables $x \text{ mod } 2\pi, \omega$, the dynamics of gas particles in Π is described by the equations

$$\dot{x}_s = \omega_s, \quad \dot{\omega}_s = 0 \quad (s = 1, \dots, n). \tag{2.2}$$

3. The first theorem on diffusion

Equations (2.2) describe an evolution of the integrable system. A phase space

$$\mathbb{P}^{2n} = \mathbb{P}^n \times \mathbb{T}^n = \{\omega, x \text{ mod } 2\pi\}$$

is foliated on invariant tori $\omega = (\omega_1, \dots, \omega_n) = \text{const}$, which are filled with conditionally periodic trajectories with frequencies $\omega_1, \dots, \omega_n$. For almost all $\omega \in \mathbb{R}^n$ these trajectories are everywhere dense (and, actually, uniformly distributed) on torus $\omega = \text{const}$.

Such picture is generally characteristic for completely integrable Hamiltonian systems with compact energy surfaces [15]. In a neighborhood of invariant tori it is possible to introduce the action-angle variables $x \bmod 2\pi, y$; in these variables the Hamiltonian equations take the form:

$$\dot{y}_s = 0, \quad \dot{x}_s = \omega_s(y); \quad 1 \leq s \leq n. \tag{3.1}$$

In a *nondegenerate* case, when

$$\frac{\partial(\omega_1, \dots, \omega_n)}{\partial(y_1, \dots, y_n)} \neq 0,$$

it is possible to change from variables y to new variables ω . In these coordinates equations (3.1) have form (2.2). Thus, equations (2.2) represent a *universal* form of equations of motion of nondegenerate completely integrable systems.

Let $f(\omega, x)$ be a Lebesgue integrable function, which is 2π -periodic on each of coordinates x_1, \dots, x_n . Let $g: \mathbb{T}^n \rightarrow \mathbb{R}$ be a Riemann integrable function; in particular, it means that it is restricted. Let's introduce the following function of time

$$K(t) = \int_{\mathbb{R}^n} \int_{\mathbb{T}^n} f(\omega, x - \omega t) g(x) d^n x d^n \omega. \tag{3.2}$$

Since the function $f(\omega, x - \omega t)$ is Lebesgue integrable on all values of t , and g is measurable and restricted function, integral (3.2) is correctly defined.

The function $K(t)$ has an obvious interpretation. First of all we note that it follows from equations (2.2) that $x - \omega t = x_0 = \text{const}$. Let $f \geq 0$ be (according to Gibbs) the density of distribution of integrable systems in \mathbb{P} (density of probability measure), and g be the characteristic function of Jordan measurable domain D on \mathbb{T}^n . It is clear that

$$\langle f \rangle = \int_{\mathbb{P}^n} f d^n x d^n \omega = 1.$$

It is easy to see, that in this case $K(t)$ is equal to a fraction of all the systems which phases (i. e. the x -coordinates of points on \mathbb{T}^n) belonging to the domain D .

Let's study the behavior of function $K(t)$ for $t \rightarrow \omega\infty$.

Theorem 1. *There exists*

$$\lim_{t \rightarrow \pm\infty} K(t) = \langle f \rangle \bar{g}, \tag{3.3}$$

where

$$\bar{(\cdot)} = \frac{1}{(2\pi)^n} \int_{\mathbb{T}^n} (\cdot) d^n x.$$

Let's return to the case, where f is the density of distribution of probability measure, and g is the characteristic function of measurable domain D . Then relation (3.3) transforms into the equality

$$\lim_{t \rightarrow \pm\infty} K(t) = \frac{\text{mes } G}{\text{mes } \mathbb{T}^n}. \tag{3.4}$$

Hence, independently of the initial distribution after an unbounded period of time the system becomes evenly distributed on phases. This result shows the irreversible diffusion in nondegenerate integrable systems.

We divide the proof of theorem 1 onto several items. Since a Lebesgue integrable function can be presented as a difference of two non-negative integrable functions, we shall assume $f \geq 0$.

1) Let $g(x) = \bar{g} = \text{const}$. Then

$$\int_{\mathbb{P}} f(\omega, x - \omega t) g d^n x d^n \omega = \langle f \rangle \bar{g}$$

using the formula of change of variables in a multiple integral.

2) Let $g(x) = \exp i(m, x)$, $m \in \mathbb{Z}^n$, and $m \neq 0$. By setting $u = x - \omega t$, we obtain

$$K(t) = \int_{\mathbb{R}^n} f_{-m}(\omega) e^{i(m, \omega)t} d^n \omega,$$

where

$$f_{-m} = \int_{\mathbb{T}^n} f(\omega, u) e^{i(m, u)} d^n u$$

is a Fourier coefficient of function f , considered as a function on \mathbb{T}^n , multiplied by $(2\pi)^n$. The Fubini theorem implies that the function $f_{-m}: \mathbb{R}^n \rightarrow \mathbb{R}$ is Lebesgue integrable. Hence (according to the theory of Fourier transform), $K(t) \rightarrow 0$ for $t \rightarrow \infty$.

3) Items 1 and 2 imply that theorem 1 is valid for any trigonometric polynomial g .

4) We shall now use the well-known statement from the theory of Riemann integral (compare with [16]). Let function $g: \mathbb{T}^n \rightarrow \mathbb{R}$ be Riemann integrable. Then, for all $\varepsilon > 0$, there exist two trigonometric polynomials g_1 and g_2 such that

- (a) $g_1(x) \leq g(x) \leq g_2(x)$ for all $x \in \mathbb{T}^n$,
- (b) $\bar{g}_2 - \bar{g}_1 < \varepsilon$.

The proof of this statement uses the Weierstrass approximation theorem.

5) Let

$$K_j(t) = \int_{\mathbb{P}} f(\omega, x - \omega t) g_j(x) d^n x d^n \omega; \quad j = 1, 2.$$

Since $f \geq 0$, then for all t ,

$$K_1(t) \leq K(t) \leq K_2(t).$$

According to item 3, for $t \rightarrow \infty$ the difference $K_2(t) - K_1(t)$ tends to

$$\langle f \rangle (\bar{g}_2 - \bar{g}_1) < \langle f \rangle \varepsilon. \tag{3.5}$$

Here we use property (b) from item 4.

Thus, inequality (3.5) holds for all $t > T_1(\varepsilon)$.

6) According to item 3, for all $\varepsilon > 0$ there exists $T_2(\varepsilon)$ such that for all $t > T_2(\varepsilon)$ we have

$$|K_j(t) - \langle f \rangle \bar{g}_j| < \varepsilon. \tag{3.6}$$

On the other hand, using property (a) and inequality $f \geq 0$ we obtain

$$\langle f \rangle \bar{g}_1 \leq \langle f \rangle \bar{g} \leq \langle f \rangle \bar{g}_2. \tag{3.7}$$

Inequalities (3.5)–(3.7) imply that for $t > \max(T_1(\varepsilon), T_2(\varepsilon))$ the inequality is fulfilled

$$|K(t) - \langle f \rangle \bar{g}| < 3 \langle f \rangle \varepsilon$$

■

These arguments are similar to the proof of the Weyl uniform distribution theorem [16]. As a matter of fact, Poincaré does not give the precise formulation of the statement on the limit uniform phase distribution. He considers only item 2 in the special case of $n = 1$, assuming that the function f is continuously differentiable with respect to ω .

4. Equalization of density

Let $f(\omega, x) \geq 0$ be the density of distribution of gas particles in a phase space for $t = 0$, and $g(z)$ be the characteristic function of a measurable domain G in Π^n . By definition of density, $\langle f \rangle = 1$. On the other hand, using the explicit formulas for 2^n -leaf covering $\mathbb{T}^n \rightarrow \Pi^n$, we obtain

$$\bar{g} = \frac{1}{l_1 \dots l_n} \int_{\Pi^n} g(z) d^n z = \frac{\text{mes } G}{\text{mes } \Pi}. \quad (4.1)$$

Hence, by theorem 1,

$$\lim_{t \rightarrow \pm\infty} K(t) = \frac{\text{mes } G}{\text{mes } \Pi}.$$

Thus, after some period of time t a fraction of gas particles, which are situated in the domain $G \subset \Pi$, is proportional to the volume of G . So, we come to the following result (formulated by Poincaré [12]): independently of the initial distribution of f , for $t \rightarrow +\infty$ and $t \rightarrow -\infty$ the density of gas in the vessel Π will be irreversibly equalized. Let's emphasize once again that the diffusion of a collisionless medium is determined by nonuniformity of returnability of its particles to the initial positions.

Since the difference $K(t) - \text{mes } G / \text{mes } \Pi$ tends to zero, fluctuations of density of ideal gas decrease unrestrictedly with a course of time. For the Boltzmann–Gibbs gas consisting of *finite* number of particles, it is necessary, at first, to give rigorous definition of density equalization. Unfortunately, no precise theoretical results were presented for this subject so far. However, in any case (because of the Poincaré theorem on returning), equalization of densities of the Boltzmann–Gibbs gas should be accompanied by sustained fluctuations. Problems of numerical simulation of Boltzmann–Gibbs gas are discussed, for example, in paper [17].

To estimate the rate of equalization of density of ideal gas, we shall consider a simple example. We assume that the velocities of gas particles are subjected to the normal distribution:

$$f(\omega, x) = \frac{\lambda(x)}{(\sqrt{2\pi}\sigma)^n} e^{-\frac{\omega^2}{2\sigma^2}}, \quad (4.2)$$

$$\omega^2 = \omega_1^2 + \dots + \omega_n^2.$$

Here λ is the non-negative measurable function on \mathbb{T}^n , and

$$\int_{\mathbb{T}^n} \lambda(x) d^n x = 1. \quad (4.3)$$

If we interpret (4.2) as the density of Maxwell distribution then the variance σ^2 is in proportion to Kelvin temperature τ .

In the case in question we have the following equality:

$$K(t) - \frac{\text{mes } G}{\text{mes } \Pi} = \sum'_m g_m \lambda_{-m} \int_{-\infty}^{\infty} \frac{e^{-\frac{\omega^2}{2\sigma^2}}}{(\sqrt{2\pi}\sigma)^n} e^{i(m,\omega)t} d^n \omega, \quad (4.4)$$

where g_m is a Fourier coefficient of the lifting of function $g(z)$ on \mathbb{T}^n , and $(2\pi)^n \lambda_m$ is a Fourier coefficient of function $\lambda: \mathbb{T}^n \rightarrow \mathbb{R}$. By formula (4.3), we obtain a simple estimate $|\lambda_m| \leq 1$. On the other hand, using formula (4.1) we have the following inequality:

$$|g_m| \leq \frac{\text{mes } G}{\text{mes } \Pi}.$$

Hence, from (4.4) we obtain the inequality

$$\left| K(t) - \frac{\text{mes } G}{\text{mes } \Pi} \right| \leq \frac{\text{mes } G}{\text{mes } \Pi} \sum_{m \neq 0} e^{-\frac{\sigma^2 t^2(m,m)}{2}}. \tag{4.5}$$

The series on the right hand side converges for all $t > 0$ (if $\sigma \neq 0$) and its sum tends to zero extremely fast, when $t \rightarrow \pm\infty$.

The sum of a majorizing series

$$\sum_{m \neq 0} e^{-\frac{\sigma^2 t^2(m,m)}{2}} \tag{4.6}$$

is expressed in theta-functions. It is equal to

$$[\theta_3, (0, q)]^n - 1,$$

where $q = \exp(-\sigma^2 t^2/2)$, and the third theta-function is defined by the series

$$\theta_3(v, q) = \sum_{-\infty}^{\infty} q^{n^2} e^{i2\pi n v}.$$

It is clear, that $\theta_3(v, q) \rightarrow 1$ for $q \rightarrow 0$.

Estimate (4.5) is universal in a sense that it does not contain the function λ . In particular, it is possible to use Dirac's δ -function as λ . In that case, the gas at the initial moment is concentrated in one point (by the way, this situation does not contradict the hypothesis about collisionlessness of the medium). Since σ^2 is proportional to τ , series (4.6) actually depends on the combination $t\sqrt{\tau}$. Therefore, the duration of density equalization process decreases with the growth of temperature as $1/\sqrt{\tau}$.

Note that in contrast to Kac's model (and to the conventional knowledge about the mechanism of heat balance in gases) the equalization of density occurs without preliminary averaging with respect to the states and without determination.

5. The second theorem on diffusion

Let functions $f, g: \mathbb{R}^n \times \mathbb{T}^n \rightarrow \mathbb{R}$ are integrable together with their squares (with belong to class $L_2(\mathbb{P})$). It is clear that for all values of t the function $f(\omega, x - \omega t)$ also belongs to L_2 . Therefore, the function

$$K(t) = \int_{\mathbb{P}} f(\omega, x - \omega t) g(\omega, x) d^n x d^n \omega.$$

is correctly defined.

Theorem 2. *Under the above assumptions we have*

$$\lim_{t \rightarrow \pm\infty} K(t) = (2\pi)^n \int_{\mathbb{R}^n} \overline{f} \overline{g} d^n \omega. \tag{5.1}$$

This result, certainly, does not follow from theorem 1 (as well as theorem 1 is not a corollary of theorem 2). In Poincaré's paper [12] formula (5.1) is not mentioned.

Before we prove theorem 2, we shall make one auxiliary statement. Let

$$\sum f_m(\omega) e^{i(m,x)} \quad \text{and} \quad \sum g_m(\omega) e^{i(m,x)} \tag{5.2}$$

be Fourier series of functions f and g for a fixed value of ω . The Fubini theorem imply that these series are defined for almost all $\omega \in \mathbb{R}^n$. Moreover, for almost all ω the functions f and g belong to $L_2(\mathbb{T}^n)$. Hence,

$$\int_{\mathbb{T}^n} f(\omega, x - \omega t)g(\omega, x) d^n x = (2\pi)^n \sum_m f_m g_{-m} e^{-i(m,\omega)t}. \tag{5.3}$$

Since $f, g \in L_2$, then the functions $|f_m g_{-m}|$ are integrable in \mathbb{R}^n for all $m \in \mathbb{Z}^n$. Let's denote $g'_m = g_m \exp[i(m, \omega)t]$. It is clear that $g'_m g'_{-m} = g_m g_{-m}$.

Lemma 1.

$$\sum_m \int_{\mathbb{R}^n} |f_m g'_{-m} + f_m g'_m| d^n \omega < \int_{\mathbb{P}} (f^2 + g^2) d^n x d^n \omega. \tag{5.4}$$

It is a variant of the Bessel inequality. The inequality shows, in particular, that the series in the left-hand part of (5.4) converges uniformly on $t \in \mathbb{R}$.

Proof of the lemma. We shall use an obvious inequality

$$|f_m g'_{-m} + f_{-m} g'_m| \leq f_m f_{-m} + g_m g_{-m}.$$

Since f_m and f_{-m} are complex conjugate, $f_m f_{-m} \geq 0$. Similarly, $g_m g_{-m} \geq 0$.

Now we are to prove the inequality

$$\sum_m \int_{\mathbb{R}^n} f_m f_{-m} d^n \omega \leq \int_{\mathbb{P}} f^2 d^n x d^n \omega. \tag{5.5}$$

The similar inequality holds for function g .

Indeed, let f_N be the finite sum of the terms of Fourier series (5.2), such that $|m| < N$. Then

$$0 \leq \int_{\mathbb{P}} (f - f_N)^2 d^n x d^n \omega = \int_{\mathbb{P}} f^2 d^n x d^n \omega - \sum_{|m| < N} \int_{\mathbb{P}^n} f_m f_{-m} d^n \omega.$$

Hence, inequality (5.5) is valid for any finite sum of the series in the left-hand part of (5.3). We obtain the required statement by passage to the limit for $|m| \rightarrow \infty$.

Now, let's prove theorem 2. By lemma 1 (using the well-known theorems by Levy and Lebesgue) series (5.3) converges for almost all ω , and it is possible to integrate the series term-by-term. Integrating both parts of equality (5.3) over \mathbb{R}^n , we obtain the relation

$$K(t) = (2\pi)^n \int_{\mathbb{R}^n} \overline{f} \overline{g} d^n \omega + (2\pi)^n \sum_{m \neq 0} \int_{\mathbb{R}^n} f_m(\omega) g_{-m}(\omega) e^{-i(m,\omega)t} d^n \omega.$$

Since functions $f_m g_{-m}$ are Lebesgue integrable, each term of series in the right-hand side tends to zero, when $t \rightarrow \pm\infty$. According to the lemma, this series converges uniformly on t . Therefore for any $\varepsilon > 0$ there exists $N(\varepsilon)$, such that the sum of terms of series with the indices $|m| > N(\varepsilon)$ is less than $\varepsilon/2$ for all values of t . The finite sum of remaining terms tends to zero when $t \rightarrow \pm\infty$. Hence, there exists $T(\varepsilon)$ (actually depending on $N(\varepsilon)$), such that for $|t| > T(\varepsilon)$ this sum will be less than $\varepsilon/2$. So, for $|t| > T(\varepsilon)$ the sum of series is less than ε , q.e.d.

Theorem 2 make it possible to solve the problem of evolution of density of distribution of f for $t \rightarrow \infty$. At first, the density $f(\omega, x - \omega t)$ seems to oscillate conditionally-periodically and, therefore, there is no limit for $t \rightarrow \infty$. However, the density of distribution of probabilities does not "exist" by itself, but only as an averaging of some fixed function from L_2 . Therefore, the evolution of f for $t \rightarrow \infty$ should be considered in *the generalized* sense, as it is usually done in the theory of the generalized functions (see, for example, [18]).

To understand, how integrable system (2.2) is distributed in phase space \mathbb{P} for $t \rightarrow \infty$, we shall introduce the characteristic function g of the following set

$$G = \{x \pmod{2\pi}, \omega: x'_s \leq x_s \leq x''_s, \omega'_s \leq \omega_s \leq \omega''_s, 1 \leq s \leq n\}.$$

It is clear that

$$\langle g \rangle = \begin{cases} (2\pi)^{-n} \prod_{s=1}^n (x'_s - x_s), & \text{if } \omega' \leq \omega \leq \omega'', \\ 0 & \text{for the remaining } \omega. \end{cases}$$

It is asserted that for $t \rightarrow \infty$ function $f(\omega, x - \omega t)$ converges weakly to \bar{f} . Limit density \bar{f} is an integrable non-negative function on \mathbb{R}^n , and $\langle \bar{f} \rangle = 1$.

Indeed, by theorem 2, for $t \rightarrow \infty$

$$\begin{aligned} \int_{\mathbb{P}} f(\omega, x - \omega t) g(\omega, x) d^n x d^n \omega &\rightarrow (2\pi)^n \int_{\mathbb{R}^n} \bar{f} \bar{g} d^n \omega = \\ &= \prod_{s=1}^n (x''_s - x'_s) \int_{\omega'_1}^{\omega''_1} \dots \int_{\omega'_n}^{\omega''_n} \bar{f} d\omega_1 \dots d\omega_n. \end{aligned}$$

But exactly the same result is obtained by direct computation of the average value of limiting density \bar{f} over domain G .

As an example, we consider a *nondegenerate* Hamiltonian system with one degree of freedom and show that any function of distribution from L_2 converges weakly to the function depending only on the total energy. Let's recall the definition of nondegeneracy. We assume that the whole phase space consists of finite number of pieces, invariant relatively to the phase flow; on each of such pieces it is possible to introduce action-angle variables $y, x \pmod{2\pi}$. The transition from usual canonical variables p, q to variables x, y is a symplectic transformation: its Jacobian is equal to one. In new variables, Hamiltonian $H(p, q)$ depends only on y . We call the system nondegenerate if

$$\frac{d^2 H}{dy^2} \neq 0 \tag{5.6}$$

on each of the invariant pieces. It is possible to verify, for example, that a usual pendulum in the gravity field satisfies these requirements.

In the action-angle variables the Hamiltonian equations

$$\dot{p} = -\frac{\partial H}{\partial q}, \quad \dot{q} = \frac{\partial H}{\partial p}$$

become

$$\dot{x} = \omega(y), \quad \dot{y} = 0, \tag{5.7}$$

where $\omega = \frac{dH}{dy}$ is the frequency of periodic motion.

According to (5.6), $\frac{d\omega}{dy} \neq 0$. Hence, ω is a monotonic function of y and, consequently, it is possible to change from variable y to frequency ω on each invariant piece. Then, equation (5.7) takes the universal form

$$\dot{x} = \omega, \quad \dot{\omega} = 0$$

and we can use theorem 2: the initial density f tends to the "equilibrium" limit \bar{f} , depending only on ω . By frequency, the limit density is a function of y and, hence, of H .

The attempts to prove that for $t \rightarrow \infty$ the distribution of probabilities tends (in some sense) to the stationary state that corresponds to the heat balance [19] (chapter XII) can be traced as far back as to Gibbs. According to M. Kac [4] (chapter III), the idea that probability should be introduced into mechanics *only* by means of the initial density, certainly seems to be very attractive. But, generally speaking, this point of view is, apparently, unfounded and the probability should also appear in mechanics by other ways.

In our opinion, theorems 1 and 2 on diffusion in integrable systems show the fruitfulness of Gibbs' approach and indicate that his ideas have not yet been fully realized.

6. Pressure, internal energy and the equation of state

Theorem 1 establishes the law of equalization of density of ideal gas in a rectangular parallelepiped. Theorem 2 let us prove the equalization of pressure and density of energy of ideal gas, specify the formulas for the limit values of these quantities and, thus, deduce the equation of state of gas in heat balance.

First, let's deduce the formula for the pressure of gas on one of the walls from collisions of the gas particles with this wall. The deduction of the formula for the pressure follows the classical reasoning in the elementary kinetic theory of gas (see, for example, [20]; it is usually assumed that the gas is already in heat balance and the velocity distribution is the Maxwell distribution).

For the sake of clarity, consider a wall, determined by equation $z_1 = l_1$. Let's choose an infinitely small rectangle σ with the center in point (l_1, z_2, z_3) , its area being equal to $d\sigma = dz_2 dz_3$. The particles of gas that can hit rectangle σ with velocity $\omega = (\omega_1, \omega_2, \omega_3)$ in the moment of time t were situated in the moment of time $t - dt$ on the parallel rectangle $\partial\sigma$ (Fig. 2), during period dt they sweep volume

$$dv = \omega_1 dt dz_2 dz_3.$$

The number of such particles is equal to

$$dn = N f(\omega, l_1, z_2, z_3) dv,$$

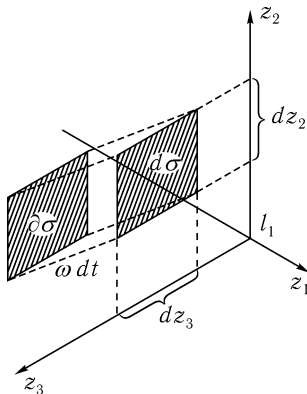

where the constant coefficient N is equal to "the number of particles of gas in the vessel". Let m be the mass of "one" particle. Then mN is the total mass of gas. Numbers m and N are of the conventional character, they are introduced for the purpose of comparison of the formulas obtained below with the known formulas of statistical mechanics. Since $\langle f \rangle = 1$, then mNf is the density distribution of the mass of gas.

During time dt the particles deliver the following impulse to the wall

$$dP = 2m\omega_1 dn = 2mN\omega_1^2 f dt d\sigma.$$

Fig. 2

It is clear that dP/dt is a force of pressure. If we divide it by the area $d\sigma$, then we shall obtain the elementary pressure on the wall in the point with coordinates l_1, z_2, z_3 . Integrating over all velocities, we shall obtain the total pressure

$$p = 2mN \int_0^\infty \int_{-\infty}^\infty \int_{-\infty}^\infty \omega_1^2 f(\omega, l_1, z_2, z_3) d\omega_1 d\omega_2 d\omega_3. \tag{6.1}$$

Let f be an even function of velocities: $f(-\omega, z) = f(\omega, z)$. Then formula (6.1) becomes more symmetric:

$$p = mN \int_{\mathbb{R}^3} \omega_1^2 f(\omega, l_1, z_2, z_3) d^3\omega. \tag{6.2}$$

Let's emphasize, that in the initial moment of time the pressure p depends on a point on a wall $z_1 = l_1$. The formula for pressure on the other walls is the same as (6.2), with only change of ω_1^2 with ω_2^2 and ω_3^2 accordingly.

REMARK 1. How shall we determine the pressure of gas in an arbitrary interior point $z \in \Pi$ on small surface with a normal vector n ? If particles of gas hit the surface from the opposite sides, then (in accordance with the assumption of evenness of the distribution function) we shall, obviously, obtain zero pressure. If we put a body of small volume into the vessel Π , then the particles of gas will hit only one side of the surface. Hence, at this moment of time the pressure can be determined by the slightly improved formula (6.2):

$$p = mN \int_{\mathbb{R}^3} (\omega, n)^2 f(\omega, z) d^3\omega.$$

Now let t go to infinity. Then, according to section 5, density f tends to "the equilibrium" state \bar{f} , depending only on ω . As a result, the pressure does not depend on the point of the wall any more:

$$p = mN \int_{\mathbb{R}^3} \omega_1^2 \bar{f} d^3\omega. \tag{6.3}$$

REMARK 2. Actually formula (6.3) requires additional justification, since in (6.2) there is no averaging by configurational space, and function $\omega \mapsto \omega_1^2$, certainly, does not belong to class L_2 . We should understand formula (6.3) differently.

Let $f(\omega, x)$ be a density function, "lifted" on direct product $\mathbb{R}^3 \times \mathbb{T}^3$. Let's assume

$$p(t) = mN \int_{\mathbb{R}^3} \omega_1^2 f(\omega, x - \omega t) d^3\omega.$$

Further, let

$$\sum_k f_k(\omega) e^{i(k,x)}$$

be a Fourier series of function f , defined for almost all $\omega \in \mathbb{R}^3$. Then

$$p = mN \int_{\mathbb{R}^3} \omega_1^2 \bar{f} d^3\omega + mN \sum_{k \neq 0} e^{i(k,x)} \int_{\mathbb{R}^3} \omega_1^2 f_k(\omega) e^{-i(k,\omega)t} d^3\omega.$$

If the functions $\omega_1^2 f_k$ are summable for all $k \in \mathbb{Z}^3$, then $p(t)$ tends to (6.3) for $t \rightarrow \infty$.

Note, if \bar{f} depends on $\omega^2 = \sum \omega_s^2$, then *the Pascal's law* is valid: the pressure in all directions is identical. In the opposite case it is not so: a fraction of the gas particles moving in different directions is not the same.

For the average kinetic energy of one particle we have the formula

$$e = \int_{\mathbb{R}^3} \int_{\Pi} \frac{m\omega^2}{2} f(\omega, z) d^3z d^3\omega.$$

If we change to σ -leaf covering $\mathbb{T}^3 \rightarrow \Pi$, we can write this formula in the following form:

$$e = \frac{l_1 l_2 l_3}{(2\pi)^3} \int_{\mathbb{R}^3} \int_{\mathbb{T}^3} \frac{m\omega^2}{2} f(\omega, x) d^3x d^3\omega.$$

The average (interior) energy of the whole gas is, obviously, equal to

$$E = \frac{mNv}{2} \int_{\mathbb{R}^3} \omega^2 \bar{f} d^3\omega, \tag{6.4}$$

where v is the volume of the vessel. The integral on the right-hand side converges if the values of pressure of gas are finite on each wall of the vessel.

If \bar{f} depends on ω^2 , then (6.3) and (6.4) imply the simple relation

$$E = \frac{3}{2}pv. \quad (6.5)$$

This formula is well known in the theory of ideal gas. Let

$$\Omega = dE + p dv \quad (6.6)$$

be a 1-form of heat inflow; it is not a total differential. In accordance with *the law of degradation of energy* of thermodynamics, for Ω there exists an integrating multiplier: $\beta\Omega = dS$, where S is an entropy, $\beta = 1/(k\tau)$, τ is Kelvin temperature, k is the Boltzmann constant. According to (6.5) the integrating multiplier for form (6.6) is equal to $(pv)^{-1}$. Hence, pv is proportional to Kelvin temperature τ , and we obtain the perfect gas law (the Clapeyron equation).

It is possible to obtain this result differently, assuming

$$\bar{f} = c\rho\left(\beta\frac{m\omega^2}{2}\right), \quad (6.7)$$

where $\beta = 1/(k\tau)$, k is the Boltzmann constant, c is a normalized multiplier:

$$c^{-1} = v \int_{\mathbb{R}^3} \rho\left(\beta\frac{m\omega^2}{2}\right) d^3\omega. \quad (6.8)$$

The distributions of form (6.7) were studied in paper [8]; the classical Maxwell distribution also belongs to this type.

After a change $\omega_s = \tilde{\omega}_s/\sqrt{m\beta}$ we obtain

$$c^{-1} = \frac{v}{(\sqrt{m\beta})^3} \int_{\mathbb{R}^3} \rho\left(\frac{\tilde{\omega}^2}{2}\right) d^3\tilde{\omega},$$

$$E = \varkappa \frac{Nk\tau}{2}, \quad \varkappa = \frac{\int_{\mathbb{R}^3} \tilde{\omega}^2 \rho\left(\frac{\tilde{\omega}^2}{2}\right) d^3\tilde{\omega}}{\int_{\mathbb{R}^3} \rho\left(\frac{\tilde{\omega}^2}{2}\right) d^3\tilde{\omega}}.$$

For the Maxwell distribution $\varkappa = 1$. In paper [8] a class of non-Maxwell distributions was described, for which the equality $\varkappa = 1$ also holds.

7. Entropy

As it is known, the entropy is determined by equality

$$S = - \int_{\mathbb{P}} f(\omega, x) \ln f(\omega, x) d^m x d^m \omega, \quad (7.1)$$

where f is a function of distribution of probabilities. For the Maxwell distribution it coincides with the notion of entropy used in the equilibrium thermodynamics.

The question is, what is the evolution in time of the entropy in the case in question, when the gas is represented as a collisionless continuous medium. It is important to emphasize, that the evolution of state of gas is *an adiabatic process*: there is no energy transfer.

To express S as a function of time, it is necessary to substitute x with $x - \omega t$ in the integrand of (7.1). However, for such substitution integral (7.1) does not change and S as a function of time is constant.

This simple observation corresponds to the Poincaré’s result [12] that the *fine* entropy of mathematicians, in contrast to the *rough* entropy of physicists, is always constant. By the way, the division of the entropy into the fine and the rough corresponds essentially to the fine-grain structure and coarse-grain structure of the phase space, that was introduced by T. Ehrenfest and P. Ehrenfest in their well-known work [2].

It is possible to approach the problem of behavior of the entropy from the other side. We already saw in section 5, that the function of distribution $f(\omega, x - \omega t)$ for $t \rightarrow \infty$ tends in the generalized sense to the average value \bar{f} , depending only on ω . Let’s assume that

$$S_\infty = -(2\pi)^n \int_{\mathbb{R}^n} \bar{f} \ln \bar{f} d^n \omega. \tag{7.2}$$

This expression can be interpreted as an entropy in steady equilibrium state. By the way, formula (7.2) can be obtained by theorem 2, using expression $g = \ln f$.

The following inequality

$$S \leq S_\infty, \tag{7.3}$$

expresses *the law of degradation of energy* of thermodynamics for irreversible processes.

To prove (7.3) we shall fix the value of ω and then denote $f(\omega, x)$ as $\rho(x)$. Now, we establish the inequality

$$\overline{\rho \ln \rho} \geq \bar{\rho} \ln \bar{\rho}.$$

It is in turn equivalent to the discrete inequality

$$\sum \rho_i \ln \rho_i \geq \left(\sum \rho_i \right) \ln \sum \rho_i$$

for the positive ρ_i , which is the special case of the Jensen inequality for a convex function $\rho \mapsto \rho \ln \rho$. ■

As Poincaré has noted [12], the values of entropy can be compared only in the states of steady equilibrium.

Let’s consider a simple, but instructive example. Let vessel Π be divided by a barrier into two parts and the gas be initially concentrated in one of the parts of Π , and in heat balance. Its entropy we shall denote by S_- . Now we remove the barrier. The gas will extend adiabatically, uniformly filling (by theorem 1) the whole volume of Π . Let S_+ be the entropy of gas after the establishment of heat balance, that will happen after an infinite time. Accordingly to (7.3), $S_- \leq S_+$. Moreover, it is possible to show that this case involves the following simple relation:

$$S_+ = S_- + \ln \frac{v_+}{v_-}, \tag{7.4}$$

where $v_-(v_+)$ is the volume of $\Pi_-(\Pi)$.

Indeed, let f_- be a density of distribution of gas, being in heat balance in vessel Π_- ; this function depends only on velocity ω . Then, obviously, $S_- = -v_- J$, where

$$J = \int_{\mathbb{R}^n} f_- \ln f_- d^n \omega.$$

After removal of the barrier the equilibrium is broken and the density $f(\omega, z)$ now depends on the point $z \in \Pi$: in the initial moment $f = f_-$, if $z \in \Pi_-$ and $f = 0$, if $z \in \Pi \setminus \Pi_-$. Theorem 2 implies

that for $t \rightarrow \infty$ density f tends in generalized sense to the average value

$$\bar{f} = \frac{1}{v_+} \int_{\Pi} f d^n z = \frac{v_-}{v_+} f_-.$$

Finally,

$$\begin{aligned} S_+ &= -v_+ \int_{\mathbb{R}^n} \frac{v_-}{v_+} f_- \ln\left(\frac{v_-}{v_+} f_-\right) d^n \omega = \\ &= -v_- J - v_- \int_{\mathbb{R}^n} f_- d^n \omega \ln \frac{v_-}{v_+} = S_- + \ln \frac{v_+}{v_-}. \end{aligned}$$

The formula (7.4) coincides with the well-known formula of the increase of entropy for the process of free expansion of gas into the void. However, we have obtained this formula, not basing on the laws of thermodynamics, but using only the law of motion of ideal gas as a collisionless medium.

8. The change of the vessel shape

Will our deductions change if we replace the rectangular parallelepiped with a surface of arbitrary shape? This problem has the principal value, not only from the point of view of thermodynamics.

The matter is that trajectories of particles of gas are essentially the light rays. Therefore, the problem can be reformulated in terms of geometrical optics. Let's put a light source (probably distributed) inside the closed reflecting surface. The question is, will the illumination inside this surface be constant or will it depend on the coordinates? Actually the related problem also arises if we consider the radiation in a closed volume with the beam approach (see, for example, [21]). The above question is traditionally answered positively. But, in this situation together with the arguments of dynamical character the requirement of heat balance is usually used. By the way, Poincaré himself made contradictory statements on this subject (see [22]).

Actually the answer is certainly negative, and it is easy to understand, bearing in mind the presence of focal points and caustics. As a simple example, it is possible to consider the vessel having a shape of ellipse and put the light source in one of the focuses. It is easy to understand, that the resulting illumination will concentrate on the transversal line of ellipse (by the way, it is unstable). If the light source is not located in the focus, the illumination intensity inside the ellipse will be variable. The existence of a limit distribution in this case (as well as in any other integrable problem) follows from theorem 2. If billiard is not integrable, the existence of a limit density of distribution presents an interesting problem.

In some sense, any billiard can be arbitrarily precisely approximated by an integrable billiard. On a plane it is a polygon, with angles comparable to π (see, for example, [23]). Except for the integral of energy, such systems allow the integral in the form of velocity polynomial. For example, in case of the rectangle the additional integral has the power 2 (squared projection of velocities on any of the sides is preserved). It is easy to understand, that the billiards showed in Fig. 3 share the same property. Using the integrability of these systems, with the help of theorems 1 and 2, it is possible to study diffusion of ideal gas as a collisionless medium in vessels of the indicated shape and, in particular, to study the processes of diffusion and mixture of gases in vessels with barriers.

So, the indicated mechanism of irreversible diffusion of collisionless medium is not universal. However, for the rarefied gases it should be considered together with the mechanism of chaotization based on molecular collisions. According to Poincaré, after a time, sufficient enough to let every particle go the whole length of the vessel several times, but short enough for the collisions not to be too numerous, the mode will be established in gas that corresponds to the equilibrium state of a collisionless continuous medium. But this equilibrium will not be final, the collisions will try to break it, and only after a much larger time interval the gas will at last reach the final heat balance.

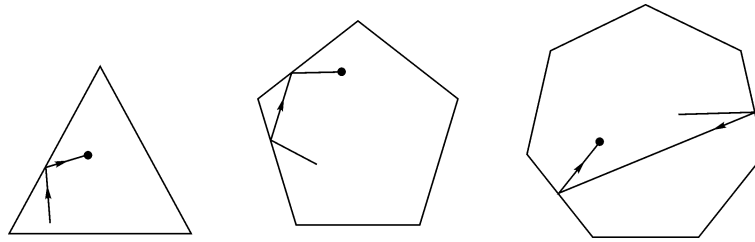

Fig. 3

By the way, “a strange kinetics” with participation of the dynamic demon of Maxwell discovered in papers [13, 14], is also based on consideration of a collisionless medium. The numerical calculations show that the density of gas is not equalized in vessels, made up from scattering billiards. As we just have shown, the similar effect occurs for integrable billiards. The strangeness of kinetics disappear as soon as we begin to take into account the interaction of particles of gas.

In conclusion of the paper we shall make two remarks.

Let’s consider a nondegenerate and quite integrable Hamiltonian system, which is described by equations (2.2) in each invariant domain $D \times \mathbb{T}^n$ of the phase space, where D is a domain in $\mathbb{R}^n = \{\omega\}$. Let’s perturb slightly the Hamiltonian function. Though the perturbed system is not integrable any more, the majority (in the sense of Lebesgue measure) of invariant tori do not disappear, but become only slightly deformed (*the Kolmogorov’s theorem* on persistence of conditionally- periodic motions). When the Hamiltonian function is sufficiently smooth the dynamics on the invariant set of large measure will be described again by equations (2.2), but now $\omega \in D \setminus M$, where $\text{mes } M \rightarrow 0$, when the perturbation disappears [15]. In this situation theorems 1 and 2 will be still valid, but the density of distribution of probabilities f must be equal to zero on the direct product $M \times \mathbb{T}^n$ (in the gap between *Kolmogorov tori*). Thus, it is possible to speak about the diffusion of perturbed Hamiltonian system on the invariant Kolmogorov set. Note that $D \setminus M$ has the structure of a Cantor set; in particular, it is nowhere dense in D .

Note also that the limit density of distribution \bar{f} can be obtained by averaging of function f over trajectories of system (2.2). Let’s assume that

$$\tilde{f}(\omega, x) = \lim_{T \rightarrow \infty} \frac{1}{T} \int_0^T f(\omega, x - \omega t) dt. \tag{8.1}$$

The Weyl theorem implies that this limit exists for all phases x and $\tilde{f}(\omega, x) = \bar{f}(\omega)$ for all *nonresonance* sets of frequencies $\omega = (\omega_1, \dots, \omega_n)$. We know that the frequencies $\omega_1, \dots, \omega_n$ are *in resonance*, if $k_1\omega_1 + \dots + k_n\omega_n = 0$ for certain integer k_s , not all of which are equal to zero. Since the resonance sets $\omega \in \mathbb{R}^n$ amount to a set of zero Lebesgue measure, then, from the point of view of the measure theory, functions \tilde{f} and \bar{f} are equivalent. The function \tilde{f} is continuous for nonresonance values ω and, in general, is discontinuous on a set of the resonance tori [24] (as a classical example of Riemann function, continuous in irrational and discontinuous in rational points of the real axis).

Let’s consider now a dynamical system, more general than (2.2). It is defined by the autonomous system of differential equations

$$\dot{x} = v(x, \omega), \quad \dot{\omega} = 0 \tag{8.2}$$

on a direct product $\mathbb{P} = \Lambda \times \mathbb{R}^m$, where $\Lambda = \{x\}$ is a compact n -dimensional manifold; v is a smooth vector field on Λ with an invariant measure $d\mu = \lambda(x, \omega) d^n x$:

$$\sum \frac{\partial(v_i \lambda)}{\partial x_i} = 0.$$

In contrast to (2.2), the dimensions m and n do not coincide. For example, for $m = 1$ equations (8.2) describe the Hamiltonian systems with compact energy manifolds; the total energy of the system acts as variable ω .

Let $f(\omega, x)$ and $g(\omega, x)$ be the functions, summable with a quadrate, defined on the phase space \mathbb{P} . Following the construction of (3.2), we consider the function

$$K(t) = \int_{\mathbb{P}} f(\omega, g^{-t}(x, \omega))g(\omega, x) d^m\omega d\mu, \tag{8.3}$$

where g^t is a phase flow of system (8.2). For the purposes of justification of the kinetics of a collisionless continuous medium in the general case, we shall prove the following statement: if for almost all ω the dynamical system $\dot{x} = v(x, \omega)$ is ergodic on Λ , then

$$\lim_{t \rightarrow \infty} K(t) = \int_{\mathbb{R}^m} \overline{fg} \text{mes } \Lambda d^m\omega, \tag{8.4}$$

where

$$\overline{(\cdot)} = \frac{1}{\text{mes } \Lambda} \int_{\Lambda} (\cdot) d\mu, \quad \text{mes } \Lambda = \int_{\Lambda} d\mu.$$

The relation (8.4) contains the formula (5.1) as a subcase.

Note that if for almost all ω the dynamical system on Λ has the *mixing* property the formula (8.4) is, certainly, valid. Indeed, for fixed ω (by definition of mixing)

$$\int_{\Lambda} f(\omega, g^{-t}(x, \omega))g(\omega, x) d\mu \rightarrow \frac{1}{\text{mes } \Lambda} \int_{\Lambda} f d\mu \int_{\Lambda} g d\mu \tag{8.5}$$

for $t \rightarrow \infty$ (see, for example, [25]). Then we should integrate this relation over \mathbb{R}^m .

It is important to emphasize, that the system $\dot{x} = \omega$ on torus is not mixing. In this case when proving of (8.4), we essentially use an averaging on ω and the property of Fourier transform.

Note that for ergodic systems without mixing relation (8.5) is valid only for *Cesaro convergence*, when the left-hand part is time averaged (as in (8.1)) (see [25]). However, the time averaging (characteristic for the ergodic theorems by von Neumann and Birkhoff) should be replaced with the averaging by ω in our case. Note, that in Kac's circular model there is also an additional averaging over all the possible states of the set M , which is used in description of the dynamics of white and black balls.

Let $\Lambda = \mathbb{T}^n$ and the field v does not depend on x . Then it is possible to set $\lambda = 1$ and, consequently, $\text{mes } \Lambda = (2\pi)^n$. Formula (8.4) is obviously valid in this case if we assume that m -dimensional surface $\omega \mapsto v(\omega)$ in $\mathbb{R}^n = \{v\}$ is transversal to the resonance planes $(k, v) = 0, k \in \mathbb{Z}^n \setminus \{0\}$. The problem of validity of (8.4) in the general case is still open.

The paper is prepared with the financial support of RFBR (99-01-01096) and the "Leading scientific groups" grant (00-15-96146).

References

- [1] *L. Boltzmann*. Vorlesungen über Gastheorie. Bd. 1–2. Leipzig: J. A. Barth. 1895–1898.
- [2] *P. Ehrenfest, T. Ehrenfest*. Begriffliche Grundlagen der Statistischen Auffassung in der Mechanik. Enzyklopädie der Math. Wiss. Bd. IV. 1911.
- [3] *G. E. Uhlenbeck, G. W. Ford*. Lectures in statistical mechanics. Amer. Math. Soc. 1963.
- [4] *M. Kac*. Probability and related topics in physical sciences. Interscience Publishers. 1957.

- [5] *M. Kac*. Some probability problems of physics and mathematics. M.: Nauka. 1967. (In Russian)
- [6] *M. P. Vukalovich, I. I. Novikov*. The equation of state of real gases. M.-L.: Gos. energeticheskoe izd-vo. 1948. (In Russian)
- [7] *V. V. Kozlov*. Thermodynamics of Hamiltonian systems and Gibbs distribution. Doklady RAN. 2000. V. 370. №3. P. 325–327.
- [8] *V. V. Kozlov*. Billiards, invariant measures, and equilibrium thermodynamics. Reg. & Chaot. Dyn. 2000. V. 5. №2. P. 129–138.
- [9] *V. I. Arnold*. Theory of catastrophes. M.: Nauka. 1990. (In Russian)
- [10] *J. M. Burgers*. The Nonlinear Diffusion Equation. Dordrecht. D. Reidel. 1974.
- [11] *V. V. Kozlov*. The general theory of vortexes. Izhevsk: Publ. house “Udmurt university”. 1998. (In Russian)
- [12] *H. Poincaré*. Réflexions sur la théorie cinétique des gaz. J. Phys. théoret et appl., 4-e sér. 1906. V. 5. P. 369–403.
- [13] *G. M. Zaslavsky*. From Hamiltonian chaos to Maxwell’s Demon. Chaos. 1995. V. 5. №4. P. 653–661.
- [14] *G. M. Zaslavsky*. Chaotic Dynamics and the Origin of Statistical Laws. Physics Today. 1999, Aug., part 1. P. 39–45.
- [15] *V. I. Arnold, V. V. Kozlov, A. I. Neishtadt*. Mathematical Aspects of Classical and Celestial Mechanics. Sec. Ed. Springer-Verlag. 1993.
- [16] *H. Weyl*. Über die Gleichverteilung von Zahlen mpd Eins. Math. Ann. 1916. Bd. 27, S. 313–352.
- [17] *I. Prigogine, C. George, F. Henin, L. Rosenfeld*. Unified Formulation of Dynamics and Thermodynamics. Chemica Scripta. 1973. V. 4. P. 5–32.
- [18] *P. Antosik, J. Mikusinski, R. Sikorski*. Theory of Distribution. The Sequential Approach. 1973.
- [19] *W. Gibbs*. Elementary principles in statistical mechanics, developed with especial reference to the rational foundation of thermodynamics. N. Y. 1902.
- [20] *V. G. Levich*. Introduction into statistical physics. M.: Gostechizdat. 1954.
- [21] *A. Sommerfeld*. Thermodynamik und Statistik. Wiesbaden. 1952.
- [22] *H. Poincaré*. Calcul des probabilités. Paris, Gauthier-Villars. 1912.
- [23] *V. V. Kozlov, D. V. Treshchev*. Billiards. A Genetic Introduction to the Dynamics of Systems with Impacts. Providence. Amer. Math. Soc. 1991.
- [24] *V. V. Kozlov*. Methods of a qualitative analysis in rigid body dynamics. NIC RCD. 2000. (In Russian)
- [25] *P. S. Halmos*. Lectures on Ergodic Theory. Tokyo. The Math. Soc. of Japan. 1956.

